



# E-1 LED LOW PROFILE THERMOPLASTIC EMERGENCY UNIT



PROJECT: \_\_\_\_\_  
 FIXTURE TYPE: \_\_\_\_\_  
 LOCATION: \_\_\_\_\_  
 CONTACT/PHONE: \_\_\_\_\_



## DIMENSIONS

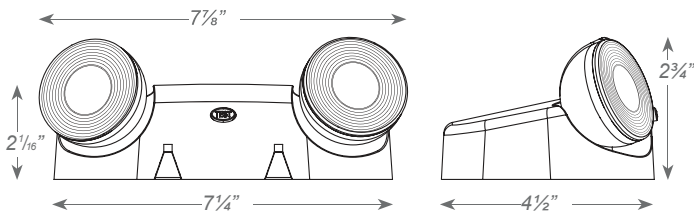

## ILLUMINATION

- Adjustable long lasting, efficient, ultra bright white LED lamp heads.
- One, 0.5 watt white LED per lamp head.
- Unique all-inclusive lamp, reflector and lens assembly.

## HOUSING

- Injection-molded, engineering grade, 5VA flame retardant, high-impact resistant, thermoplastic in white or black finish.

## MOUNTING

- Suitable for wall or ceiling mount.
- Universal knockout pattern on back plate for surface mount.

## ELECTRICAL

- Dual 120/277 voltage standard. Optional dual 120/230 voltage available.
- Unique bi-color LED indicator light alerts occupant on battery condition (Green-normal, Red-check battery).
- 3.6V long life, maintenance-free, rechargeable NiCd battery.
- Internal solid-state transfer switch automatically connects the internal battery to LED lamp heads for minimum 90-minute emergency illumination.
- Fully automatic solid-state, two rate charger initiates battery charging to recharge a discharged battery in 24 hours.

## OPTIONS

- RC: Remote capacity of up to 1.0 watt.
- SPV: UL listed for 120/230 Volt, 50/60 Hz.

## WARRANTY & LISTING

- One year warranty on all electronics and housing. Battery prorated for one year.
- UL Listed for damp locations (0°C – 40°C).
- Meets UL924, NFPA 101 Life Safety Code, NEC, OSHA, Local and State Codes.
- Certified to CEC under Title 20 Regulations.

## ORDERING INFORMATION

Model	Housing Color	Options
E-1	(blank) = White B = Black	RC = Remote Capacity SPV = 120/230 Volt 50/60Hz HL = High Lumen

Example: E-1





# E-1 LED LOW PROFILE THERMOPLASTIC EMERGENCY UNIT



PROJECT: \_\_\_\_\_  
 FIXTURE TYPE: \_\_\_\_\_  
 LOCATION: \_\_\_\_\_  
 CONTACT/PHONE: \_\_\_\_\_

## SPECIFICATIONS: ELECTRICAL

Internal solid-state transfer switch automatically connects the internal battery to LED lamp heads for minimum 90-minute emergency illumination. The operating temperature is from 32°F up to 86°F (0°C to 30°C).

## SPECIFICATIONS: BATTERY

The E-1 is supplied with a 3.6V long life, maintenance free nickel cadmium (Ni-Cd) battery, that provides a minimum emergency duration of 90 minutes. Unique bi-color LED indicator light alerts occupant on battery condition (Green-normal, Red-check battery). Fully automatic solid-state, two rate charger initiates battery charging to recharge a discharged battery in 24 hours.

## SPECIFICATIONS: MECHANICAL

The E-1 features a unique all inclusive lamp, reflector and lens assembly. UL listed for damp locations. The E-1 is ideal for use in hotels, offices, restaurants and other commercial applications.

## PERFORMANCE

Power (W)	Lumen Output (lm)	Spacing (m / ft)	
0.89 W	84lm (42 lm each)	1 fc ave 1 fc min	16 ft (min= 0.4fc) 9 ft
Battery Specifications: 3.6V long life, maintenance-free, rechargeable Ni-Cd battery.			

## ELECTRICAL RATING

Operation	Voltage (V)	Current	Wattage (W)
AC	120V	0.01A	0.89W
	277V	0.01A	0.75W
DC	3.6V	0.27A	0.97W

## PHOTOMETRICS

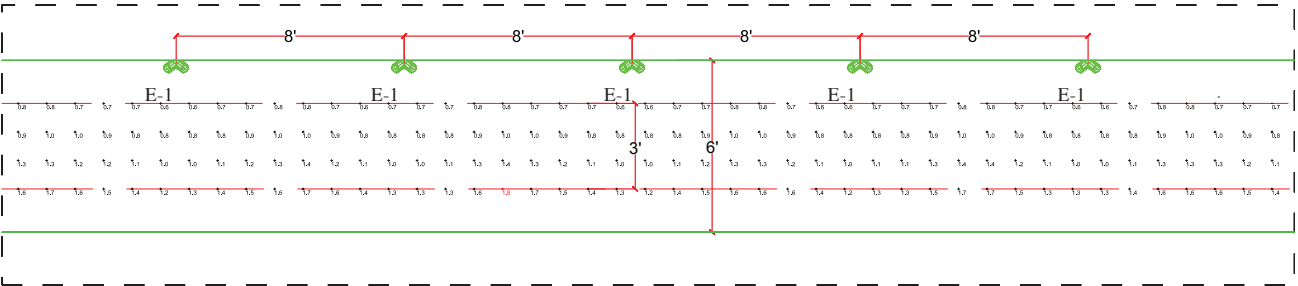

Avg = 1.05 fc  
 Min = 0.6 fc  
 MH = 7.5 feet

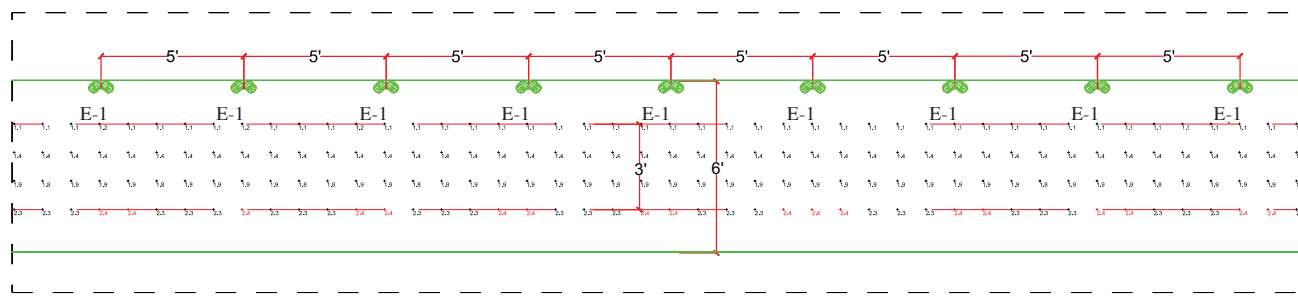

Avg = 1.68 fc  
 Min = 1.1 fc  
 MH = 7.5 feet



# E-1 LED LOW PROFILE THERMOPLASTIC EMERGENCY UNIT



PROJECT: \_\_\_\_\_  
 FIXTURE TYPE: \_\_\_\_\_  
 LOCATION: \_\_\_\_\_  
 CONTACT/PHONE: \_\_\_\_\_

## SPACING DIAGRAMS

3ft Path Spacing

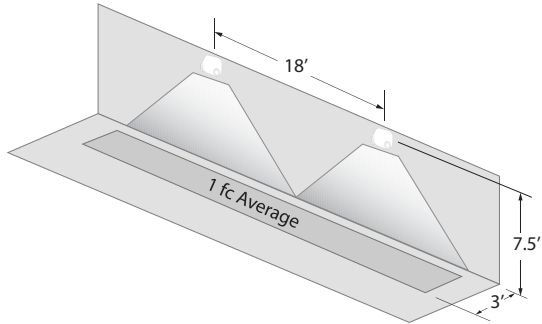

6ft Path Spacing

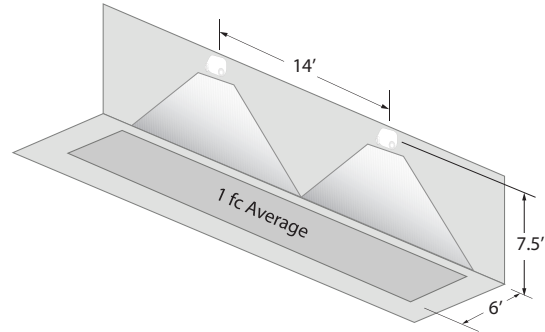

## SPACING DETAILS

Model #	Mount Height (ft)	3FT Width Egress Path		6FT Width Egress Path		Lumen per luminaire	luminaire quantity
		Single Fixture (ft)	Fixture To Fixture (ft)	Single Fixture (ft)	Fixture To Fixture (ft)		
E-1	7.5	10	14	N/A	N/A	42	2
	10	8	12	N/A	N/A		
E-1-HL	7.5	35	38	N/A	N/A	110	2
	10	8	38	N/A	N/A		