



# CHEM Series City of Chicago Steel LED Emergency Lighting



PROJECT: \_\_\_\_\_  
 FIXTURE TYPE: \_\_\_\_\_  
 LOCATION: \_\_\_\_\_  
 CONTACT/PHONE: \_\_\_\_\_



## FEATURES

- Suitable for City of Chicago
- 20 Gauge steel enclosure
- Two adjustable long-life LED lamp heads
- Maintenance-free LiFePO4 battery
- Remote capable
- Up to 62' on-center spacing

## SPECIFICATIONS

### Illumination

Two long-life, high-intensity LED lamp heads with (3) LEDs per lamp head. Two 2.85W lamp heads provide 396 lumens each, rotates vertically 0°- 90° from nadir and rotates horizontally 0°- 350°. Lamp heads may be mounted on top or on side of unit

### Housing

20 Gauge steel with a white powder coated finish

### Battery

Maintenance-free LiFePO4 battery

### Electrical Input

Universal input voltage - 120 to 277VAC, 50/60Hz

### Operating Temp

5°C to 45°C (41°F to 113°F)

### Run Time

UL Listed 90 minute emergency run time, 24 hour recharge time

### Electrical

Low voltage disconnect eliminates deep discharge, brownout, short circuit and overload protection

### Mounting

Wall mounted using a universal J-box mounting pattern or rear keyhole slots; knockouts for conduit entry on side and top provided

### Finishes

White

### Options

RC = Remote Capacity - 9.6V, 3W (6.8W total) (one additional double lamp head or two single lamp heads, see CRM Indoor Remote or R-ASR Outdoor Remote for more information)

### Certifications

UL 924 Damp Location Listed, meets or exceeds City of Chicago, NEC requirements and NFPA 101

### Warranty

Any component that fails due to a manufacturing defect is guaranteed for five years with a separate five year prorated warranty on the battery. The warranty does not cover physical damage, abuse or instances of uncontrollable natural forces. See the full Mule warranty document for detailed information (Terms and Conditions apply)

## PRODUCT DESCRIPTION

The CHEM Series is a low-profile, compact, LED emergency lighting unit that combines performance and dependability for the City of Chicago. The CHEM Series features a Lithium Ion class battery coupled with durable 20 gauge steel construction with a white powder coated finish providing scratch and corrosion resistance. Operates for a minimum of 90 minutes during a power outage. Fixture may be back mounted; side and top knockouts included.

## DIMENSIONS

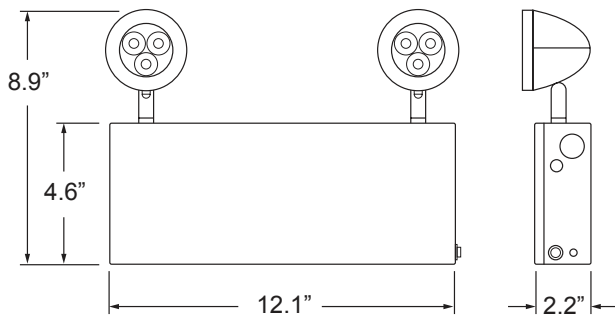

## ORDERING INFORMATION

Model	Options (Factory Installed)
CHEM = City of Chicago	RC <sup>1</sup> = Remote Capacity, 3W (6.8W total)
Steel LED Emergency Unit, White Finish	

### Notes

<sup>1</sup> Compatible with CRM Indoor Remote or R-ASR Outdoor Remote

EXAMPLE: CHEM-RC





### CONSTRUCTION

The CHEM Series is die-formed 20 gauge steel housing with with a white powder coated finish providing scratch and corrosion resistance. Universal J-box mounting pattern and keyhole slots provided for simple installation. Knockouts are provided on top, back, and sides for easy wire entry. Can also be shelf mounted – ordered separately.

### ILLUMINATION

The emergency lights consist of two long-life, high-intensity LED lamp heads with (3) LEDs per lamp head. Each 2.85W lamp head provides 396 lumens, rotates vertically 0°- 90° from nadir and rotates horizontally 0°- 350°. Lamp heads may be mounted on top or side of sign.

### ELECTRICAL

#### Input

Universal input voltage - 120 to 277VAC @ 50/60Hz. Overload and short circuit protection included.

#### LiFePO4 Battery

Maintenance-free, long-life, rechargeable LiFePO4 batteries. Fully automatic, solid-state charger initiates battery charging to recharge a discharged battery within 24 hours. The internal solid-state transfer switch automatically connects the internal battery to power the LED board for a minimum of 90 minutes of illumination during the loss of utility power. An LED indicator light alerts occupant on battery condition (Steady-normal, Blinking-check battery).

#### Emergency

The CHEM Series exit will operate for a minimum of 90 minutes during a loss of power with a 24 hour maximum recharge time for the battery.

#### Brownout Circuit

Brownout circuit monitors the line voltage. As the line voltage sags and can no longer illuminate the exit sign to meet UL 924 visibility test, the emergency circuit will turn on to supply a portion or all the power to illuminate the sign for 90 minutes until line voltage is restored.

#### SAMPLE PHOTOMETRICS - 3' PATH OF EGRESS

Using multiple CHEM units mounted at a typical 7.5' height delivers 62' on-center spacing with a 3' wide path of egress using 80/50/20 reflectances.

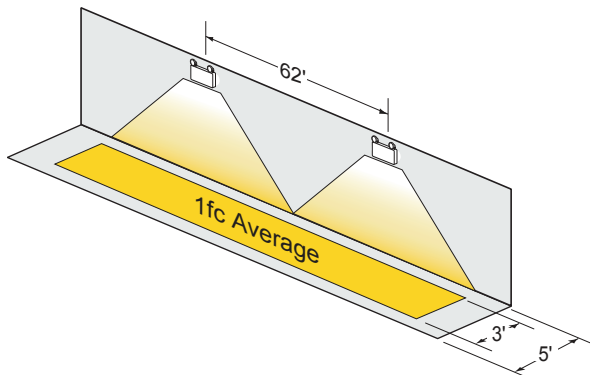

### LOW VOLTAGE DISCONNECT

Low Voltage Disconnect (LVD) measures the battery terminal voltage. The LVD continuously monitors the battery terminal voltage and if it should fall below a preset voltage threshold, the LVD will disconnect the load. When the battery is recharging and voltage is raised above another preset voltage threshold, the load is automatically reconnected.

### SOLID-STATE TRANSFER

The circuit features solid-state switching for emergency lamps, eliminating concerns of damaged contact or mechanical failures associated with relays. The switching circuit detects a loss of line voltage and automatically switches to emergency mode.

### OVERLOAD AND SHORT CIRCUIT PROTECTION

The overload monitoring system is a solid-state circuit which monitors the lamp load and disconnects from the battery should an overload or short circuit occur. The overload current protection eliminates the need for fuses or circuit breakers for the DC load.

### TEST BUTTON

The test button is easy to locate and provides manual verification of the transfer circuit, battery condition and emergency lamps.

### INSTALLATION

Installs in minutes with easy-to-read instructions and detailed diagrams. A universal knockout pattern on the rear for direct mounting to junction box and keyhole slots are provided for wall surface mounting. Knockouts are included on top and sides for easy wire entry. Can also be shelf mounted – ordered separately. No special hardware or tools necessary. Internally housed components and battery.

### CONFORMANCE TO CODES & STANDARDS

The CHEM Series is UL 924 Listed for Damp Locations and meets or exceeds the following: City of Chicago Fire Code, NEC requirements and NFPA 101.

#### SAMPLE PHOTOMETRICS - 6' PATH OF EGRESS

Using multiple CHEM units mounted at a typical 7.5' height delivers 61' on-center spacing with a 6' wide path of egress using 80/50/20 reflectances.

