



AMER-SEL
BABA COMPLIANT STEEL EMERGENCY LIGHT



PROJECT: _____
 FIXTURE TYPE: _____
 LOCATION: _____
 CONTACT/PHONE: _____



PRODUCT DESCRIPTION

The AMER-SEL Series emergency light is manufactured in the United States and meets BABA (Build America Buy America) requirements.

The AMER-SEL Series features a durable steel housing and is designed for commercial and industrial applications. Equipped with 25-watt incandescent lamp heads that produce 395 lumens each.

FEATURES

- Steel housing
- 12V lead-acid battery
- Push-to-test button
- BABA compliant
- UL 924 Listed
- 5-year warranty

ELECTRICAL

120/277VAC Input.

CODE COMPLIANCE

UL Listed to UL924 for the United States, NFPA, Life Safety 101, BABA.

EXTERNAL SPECIFICATIONS

The housing is constructed from 18-gauge steel housing finished with a dark gray or white powder coat. The hinged faceplate allows for easy access to internal components including the battery and circuit board.

WARRANTY

The AMER-SEL Series comes with a 5-year factory warranty. The lamps are not covered. Deliberate damage, misuse, or improper installation effectively cancel the warranty. Battery features a 20% per year pro-rata warranty.



DIMENSIONS

Heads Add 6-1/8 (15.5)
to Overall Height or Width

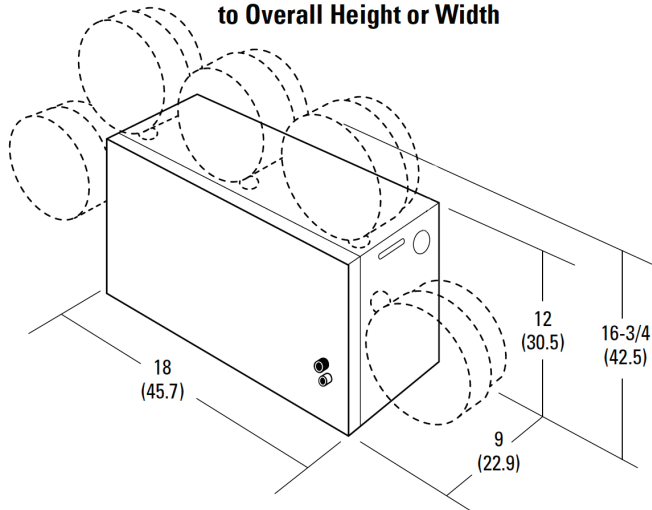

ORDERING INFORMATION

Model	Voltage	Capacity	Lamps	Housing Color
AMER-SEL	12 (12V)	125 (125W)	25W (25W Incandescent)	G (Gray)
		180 (180W)		W (White)
		275 (275W)		

Ordering Example: AMER-SEL-12-125-25W-G