



AMER-LPEM
BABA COMPLIANT THERMOPLASTIC EMERGENCY LIGHT



PROJECT: _____
 FIXTURE TYPE: _____
 LOCATION: _____
 CONTACT/PHONE: _____



PRODUCT DESCRIPTION

The AMER-LPEM Series emergency light is manufactured in the United States and meets BABA (Build America Buy America) requirements. The AMER-LPEM Series is popular for applications that require a compact emergency light that can produce powerful light. It features a low profile design and small LED lamp heads. The lens and optics provide 35-foot center-to-center spacing along a 3-foot wide path of egress.

FEATURES

- 110 lumens per lamp
- Adjustable lamp heads
- Push-to-test button
- Optional self-diagnostics
- White or black finish
- Ni-Cad battery
- UL 924 Listed
- 5-year warranty

DIMENSIONS

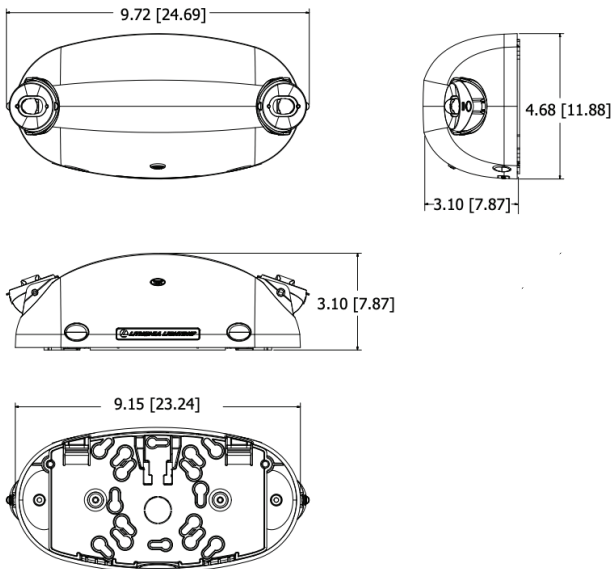

ELECTRICAL

120/277VAC Input.

CODE COMPLIANCE

UL Listed to UL924 for the United States, NFPA, Life Safety 101, BABA.

EXTERNAL SPECIFICATIONS

The housing is constructed from durable and sturdy thermoplastic that is available in a white or black finish. The lamp heads are fully adjustable.

WARRANTY

The AMER-LPEM Series comes with a 5-year factory warranty. The lamps are not covered. Deliberate damage, misuse, or improper installation effectively cancel the warranty. Battery features a 20% per year pro-rata warranty.



ORDERING INFORMATION

Model	Housing Color	Options
AMER-LPEM	WH (white)	SD (Self-Diagnostics)
	BL (black)	

Ordering Example: AMER-LPEM-WH